



Company Profile

KELLER is known for Swiss quality and precision. Ever since being established, the company has developed and produced all its products at its facilities in Winterthur.

KELLER sales engineers are on hand to provide expert advice in your native language, with more than 480 employees all around the world helping to make the company a success.

Half a century, KELLER has been pairing expertise with innovative spirit to find the right solutions for each individual application.

All of this makes KELLER the leading manufacturer of pressure transducers and pressure transmitters, certified to ISO 9001.

For People and the Company

As a company, KELLER has made major contributions to the development of modern pressure measurement technology. KELLER is proud of all its achievements and with total dedication continues in its pursuit to make a decisive difference for both its customers and employees in the future. This goal is underpinned by our shared vision and core values: Cooperation, continuous development, mutual support, courage and independence.



Sponsorship

KELLER is not only involved in the world of pressure measurement systems. For many years, the company has also supported local cultural and sporting events, including being the owner and main sponsor of the Winterthur football club.

Industry Overview

The application areas for KELLER's pressure sensors are just as broad as KELLER's product range. They measure fluid levels. They ensure perfectly brewed coffees. They identify how efficiently your motors are running, to name but a few. Put KELLER to the test.



KELLER PRESSURE
Your Swiss Pressure Sensing Specialist

KELLER in Short

Executive Management

Tobias Keller, Michael Keller

Legal Form

Privately owned corporation by Michael Keller and Tobias Keller

Founding Year

1974

Workforce

~480 employees

Annual Production

1,3 million pressure measuring cells

Pressure Ranges

5 mbar to 2000 bar

Subsidiaries

Austria, Czechia, France, Germany, Italy, Japan, Netherlands, Poland, Singapore, Spain, Sweden, UK, USA

...and sales partners all around the world.

KELLER Druckmesstechnik AG

St. Gallerstrasse 119
8404 Winterthur
Switzerland

Tel. +41 52 235 25 25
info@keller-pressure.com
www.keller-pressure.com

keller-pressure.com

KELLER Product Overview

As its core business, KELLER manufactures and sells more than 1,2 million pressure measuring cells every year. With pressure ranges from 5 mbar up to 2000 bar and a wealth of experience behind every product, KELLER solutions can be used in all manner of applications.

Pressure Transducers



Series 9L

Encapsulated piezoresistive pressure transducers for absolute and gauge pressure measurement are KELLER's core competence and lie at the heart of all KELLER products for end users. They have proved their worth millions of times over and are a reliable base for any measuring system. Transducers can be adjusted and optimised according to your needs.

Pressure Transmitters



Series 33X

Pressure transmitters are sensors that use additional electronics to compensate for linearity deviations and temperature errors, outputting measurement results as standardised signals. Every KELLER transmitter is measured over the entire pressure and temperature profile and compared to the desired signal span.

Level Probes



Series 36XW

Submersible probes for level and fill measurement. With a special design and materials including cables and housings chosen for their compatibility with their surroundings, these probes can be used in a wide range of liquids.

Digital Pressure Gauges



LE05

High-quality digital pressure gauges with easy to read displays and practical additional functions. Display units for use with KELLER transmitters or for processing standard signals from other sources.

Data Loggers



Series DCX-22

A variety of data logger designs for recording pressure and temperature profiles. Depending on the system, the data is read out via a plug connection or remote transfer.

Wireless Solutions



21D-RFID

Devices for measuring and transmitting pressure values via wireless interfaces such as LoRa, Bluetooth, 2G, 3G, 4G and RFID. Alarm notifications, switch outputs and additional extras round out the range of functions on offer.

Software

 **KELLER**
SOFTWARE

Software and device drivers for configuring KELLER products and for reading, analysing and processing the measurement data.

Accessories



K-114

Accessories, interface converters and spare parts for KELLER products.

Custom Solutions

KELLER has a strong reputation as an original equipment manufacturer. Both major customers and smaller companies appreciate the wide range of OEM products and customised solutions, which can be easily implemented into their devices.

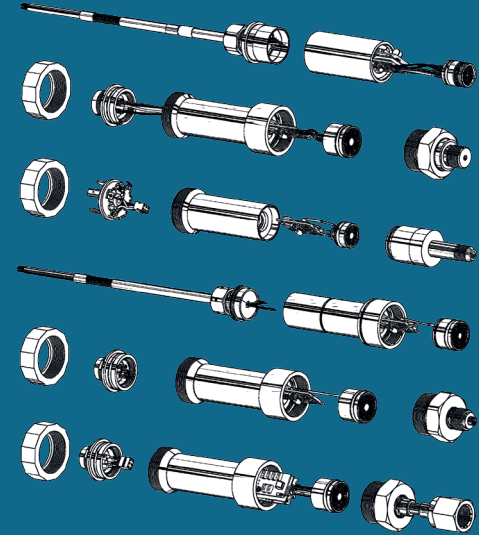

 **KELLER**

SOLUTIONS FOR YOUR APPLICATIONS

We will be happy to assist you.

Tel. +41 52 235 25 25
info@keller-pressure.com
www.keller-pressure.com